

## Functional architecture of naming dice, digits, and number words

Ardi Roelofs

*Max Planck Institute for Psycholinguistics, and F. C. Donders Centre  
for Cognitive Neuroimaging, Nijmegen, The Netherlands*

Five chronometric experiments examined the functional architecture of naming dice, digits, and number words. Speakers named pictured dice, Arabic digits, or written number words, while simultaneously trying to ignore congruent or incongruent dice, digit, or number word distractors presented at various stimulus onset asynchronies (SOAs). Stroop-like interference and facilitation effects were obtained from digits and words on dice naming latencies, but not from dice on digit and word naming latencies. In contrast, words affected digit naming latencies and digits affected word naming latencies to the same extent. The peak of the interference was always around SOA = 0 ms, whereas facilitation was constant across distractor-first SOAs. These results suggest that digit naming is achieved like word naming rather than dice naming. WEAVER + + simulations of the results are reported.

It is characteristic of humans that they intensively use a number of symbolic systems. Language and numerals are the most important ones (Deacon, 1997). Over the past two decades, there has been an increased interest in numerals and their relation to natural language (Butterworth, 1999; Dehaene, 1997; Hurford, 1987). Whereas numeral comprehension and arithmetic processes have been extensively investigated in chronometric, neuroimaging, developmental, and neuropsychological studies (for reviews, see Butterworth, 1999; Dehaene, 1997; Gelman & Gallistel, 1978; McCloskey, 1992), the adult production of spoken number words has been neglected somewhat. This is surprising, because cardinal numerals like *two*

---

Correspondence should be addressed to Ardi Roelofs, Max Planck Institute for Psycholinguistics, Wundtlaan 1, 6525 XD, Nijmegen, The Netherlands. Email: ardi@mpi.nl

I am indebted to Monique van de Ven and Sascha Oberrecht for their help in preparing and running the experiments, and to Antje Meyer, Pim Levelt, Stephen Levinson, Marc Brysbaert, Marjolein Meeuwissen, Anja Ischebeck, Joseph Tzelgov, and Daniel Algom for helpful comments.

and ordinal numerals like *second* are produced about 10 times more often than high-frequency nouns like *cat* and *dog* (estimated from CELEX; Baayen, Piepenbrock, & Gulikers, 1995). Speakers are highly proficient in producing spoken numerals like “two” in response to a variety of symbolic and nonsymbolic stimuli, such as the Arabic digit 2 or Roman numeral II, the written number word TWO, or a pair of dots. Already in the early days of experimental psychology, Cattell (1886) investigated not only the naming of pictures, colours, and words in chronometric experiments conducted in Wundt’s lab in Leipzig, but he and Bourdon (1908) also examined the time it takes to name dice, digits, and number words.

The naming of dice seems to have much in common with picture naming and the naming of written number words seems to happen like the naming of words from other classes such as nouns and verbs (Butterworth, 1999; Dehaene, 1997). However, it is much less clear how Arabic digits are named. Arabic digits are together with Roman (Latin) letters part of the orthographies of English, Dutch, and many other languages. Unlike letters, which represent sounds, digits are logograms representing whole morphemes or words. Both digits and letters are the basic elements of combinatorial symbolic systems. For example, the letters S, I, X, T, and Y and the digits 6 and 0 can be combined to yield the complex numerals SIXTY and 60. However, although digits and letters both make up the vocabulary of symbolic systems, digits also have several aspects in common with pictures and dice. For example, unlike the number words TWO and THREE, the digits 2 and 3 do not provide any clue as to how to pronounce their names, a property they share with pictures and dice.

The present article reports a series of chronometric experiments that examined the functional architecture of naming dice, digits, and number words and their relation to naming pictures and words. One of the major differences between the naming of pictures and words is that words, but not pictures, can be named without conceptual mediation (Coltheart, Rastle, Perry, Langdon, & Ziegler, 2001; Smith & Magee, 1980; Theios & Amrhein, 1989). Whereas Butterworth (1999) and Dehaene (1992, 1997) argued that Arabic digits can be named nonconceptually, just like words, Brysbaert (1995) and McCloskey (1992) claimed that the naming of digits is necessarily mediated conceptually, just like the naming of pictures. Recently, Fias, Reynvoet, and Brysbaert (2001) argued for the conceptual mediation of digit naming on the basis of the results of two number Stroop experiments.

The number Stroop task is a numerical version of the classic colour-word Stroop task (Stroop, 1935), in which participants name the ink colour of colour words (e.g., they have to say “red” to the word BLUE in red ink) or read the words aloud. Naming ink colours takes longer when the ink colours and colour words are incongruent (e.g., the word BLUE in red ink)

than when they are congruent (e.g., the word RED in red ink), whereas there is no such congruity effect in reading the words aloud (MacLeod, 1991). Similarly, in naming pictures with written distractor words superimposed, naming latencies are longer when the distractor words are incongruent (e.g., say “cat” to a pictured cat with the word DOG superimposed) than when they are congruent (CAT), whereas distractor pictures do not affect word naming latencies (Glaser & Dünghoff, 1984). Stroop-like tasks have been used extensively in chronometric and neuroimaging studies (for reviews, see Bush, Luu, & Posner, 2000; MacLeod, 1991; MacLeod & MacDonald, 2000). The number Stroop task (Flowers, Warner, & Polansky, 1979; Fox, Shor, & Steinman, 1971; Pavese & Umiltà, 1998; Windes, 1968) asks for the naming of the numerosity of a collection of digits or words while simultaneously trying to ignore the numerical value of the digits or words themselves, or alternatively, naming the digits or words while ignoring how many of them there are. Example stimuli are 2 2 2 and TWO TWO TWO. As with pictures/colours and words, the latencies of naming the numerosity of a collection of items are longer when the items themselves are number words or digits that are incongruent (e.g., say “five” to five 4s) than when they are congruent (e.g., say “five” to five 5s), which holds regardless of whether the number of items is within the subitizing (1–4) or counting domain (Pavese & Umiltà, 1998). Numerosity does not affect digit or word naming (Flowers et al., 1979).

To test whether Arabic digits are named like pictures or words, Fias et al. (2001) contrasted digits and words rather than digits/words and their numerosity. In the first experiment of Fias and colleagues, Arabic digits (0, 1, . . . , 9) were presented next to number words (the Dutch translation equivalents of NULL, ONE, . . . , NINE) on a computer screen, whereby the left-right position of the digits and words varied randomly from trial to trial. The participants had to name the digits and to ignore the words, or vice versa. Fias and colleagues observed that compared with the congruent condition (e.g., 3–THREE), incongruent number words (e.g., 3–TWO) increased the digit naming latencies, but incongruent digits did not affect the word naming latencies. According to Fias et al. (2001), the asymmetry in distractor effects between digit naming and word naming parallels the asymmetry typically found between picture/colour naming and word naming: “This asymmetry in our data is consistent with the literature of picture-word interference tasks, if we assume that Arabic numerals are processed like pictures and verbal numerals like words” (p. 245).

In a follow-up study using masked priming of digit and word naming, Reynvoet, Brysbaert, and Fias (2002) observed context effects from both digits and words in digit and word naming. Furthermore, the difference in effect between incongruent and congruent primes was equally large for

digit naming with digit primes, digit naming with number word primes, word naming with digit primes, and word naming with word primes. Reynvoet et al. (2002) argued that Fias et al. (2001) observed asymmetrical distractor effects between tasks because the targets and distractors were presented simultaneously, whereas in the study of Reynvoet et al. the masked primes preceded the targets by 114 ms. Apparently, when digits and words are presented simultaneously, distractor words interfere with digit naming but distractor digits do not interfere with word naming, as observed by Fias et al. (2001). On the other hand, when primes are preexposed, context digits affect word naming and context words affect digit naming to the same extent, as observed by Reynvoet et al. (2002).

However, unlike what Reynvoet et al. (2002) observed for masked digits and words, preexposure of pictures/colours does not affect word naming in picture-word and colour-word interference experiments (Glaser & Dünghoff, 1984; Glaser & Glaser, 1982). Glaser and Dünghoff (1984) observed that when distractor pictures were shown 100, 200, 300, or even 400 ms before the target words, reading the words was still unaffected by the pictures. Similarly, Glaser and Glaser (1982) observed that when colour patches were preexposed by 100, 200, or 300 ms in the colour-word Stroop task, there was also still no effect on word reading. In contrast, Reynvoet et al. (2002) observed that when digits were preexposed by 114 ms, they affected word reading. This suggests that effects of preexposed masked primes and distractors differ or that the digit-word asymmetry observed by Fias et al. (2001) is different from the asymmetry between pictures/colours and words. If the latter is the case, why then did Fias et al. (2001) observe the asymmetry? One cause may be that in the studies of Fias et al. (2001) and Reynvoet et al. (2002) the digits had the same size as a single letter of a corresponding word. Thus, in the study of Fias et al. (2001) it may have taken more time for the participants to perceive the small digits during word naming than to perceive the large words during digit naming (Theios & Amrhein, 1989), resulting in interference in digit naming but not in word naming (cf. Melara & Algom, 2003). The preexposure of the digits by Reynvoet et al. (2002) may have compensated for the extra time needed to perceive the digits relative to the time needed to perceive the words.

Moreover, whereas Fias et al. (2001) observed that the numerical distance between the digits and words did not affect the magnitude of the interference in digit naming, Reynvoet et al. (2002) observed that naming latencies were shorter when the numerical distance between prime and target was one (numerically near: e.g., prime 1, target 2) than when it was two (numerically far: e.g., prime 1, target 3). This was also observed by Ischebeck (2003). This effect of distance corresponds to what is typically observed with word primes in word naming (for a review, see Neely, 1991).

Reading latencies are shorter when the prime word is semantically near (e.g., prime DOG, target CAT) than when it is semantically far (e.g., prime HOUSE, target CAT). In contrast, the latencies of naming pictures (e.g., a cat) are longer rather than shorter when the distractor words are semantically near (DOG) than when they are far (HOUSE), as observed by Glaser and Dünghoff (1984), among others. Similarly, the latencies of naming the numerosity of a collection of digits or words (e.g., say “five” to five 4s) are longer when the words or digits themselves are numerically near (e.g., five 4s) than when they are far (e.g., five 3s), as observed by Pavese and Umiltà (1998), among others. Thus, the numerical distance effect of Reynvoet et al. (2002) and Ischebeck (2003) suggests that digit-word stimuli behave like word-word rather than picture-word stimuli and that digits are named like words rather than pictures.

The aim of the present experiments was to further examine the issue of the functional architecture of spoken numeral planning by testing for number Stroop congruity and incongruity effects using a wide range of stimulus onset asynchronies (SOAs), namely  $-300$ ,  $-200$ ,  $-100$  ms distractor preexposure (henceforth called *distractor-first* SOAs, indicated by a minus sign),  $0$  ms, or  $100$ ,  $200$ , and  $300$  ms distractor postexposure (*distractor-second* SOAs). If naming routes for two tasks are the same except that subprocesses (e.g., visual perception) take different amounts of time for the different input formats, then the SOA curves of distractor effects should have the same shape for the two tasks except that one of the curves is shifted forward or backward in time relative to the other curve (see Vorberg, 1985, for a mathematical proof). The experiments compared the naming of numbers presented in three different visual formats: dice, Arabic digits, and number words. Unlike number words, digits do not provide any clue as to how to pronounce their names, a property they share with pictures and dice. However, unlike pictures and dice, digits are part of a combinatorial symbolic system, a property they share with words. The experiments tested whether distractor effects of words in the naming of dice (and vice versa) pattern with the distractor effects of words in the naming of numerosity, pictures, and colours (and vice versa). If the effects for dice pattern with the effects for numerosity, pictures, and colours, this would suggest that dice naming is conceptually driven, just like numerosity, picture, and colour naming. Moreover, the experiments tested whether distractor effects for digits pattern with the effects for dice or with the effects for number words. This would provide evidence on whether digit naming is like dice naming (and numerosity, picture, and colour naming) or like word naming.

The second aim of the experiments was to test an extension of the WEAVER++ model of spoken word production (Levelt, Roelofs, & Meyer, 1999; Roelofs, 1992, 1997, 2003) to spoken numeral production

and number Stroop performance. Elsewhere (Roelofs, 2003), it was shown that WEAVER++ successfully simulates 16 classic data sets on Stroop-like performance, mostly taken from the review by MacLeod (1991), including incongruity, congruency, reverse Stroop, response set, semantic gradient, time course, stimulus, spatial, multiple task, manual, bilingual, training, age, and pathological effects. With only three free parameters taken two values each to accommodate task differences (colour naming, picture naming, word naming, manual responding), the model accounted for 96% of the variance of the 16 studies (250 data points). Moreover, WEAVER++ successfully simulated the difference in fMRI BOLD response between the incongruent and congruent Stroop conditions in the anterior cingulate cortex, one of the classic brain areas involved with Stroop task performance (Roelofs & Hagoort, 2002). It has been shown that existing models of Stroop-like effects cannot account for critical aspects of the data, whereas WEAVER++ can. WEAVER++ has not been applied yet to Stroop-like effects in naming dice, digits, and number words. So, the number domain forms a new test bed for the model.

Levelt et al. (1999) briefly discussed the planning of numerals in WEAVER++. Meeuwissen, Roelofs, and Levelt (2003) discussed the production of complex spoken numerals and reported chronometric evidence on the naming and reading of multiple digit numerals. In the present article, I restrict myself to the production of simple numerals in naming dice, single digits, and the corresponding number words. Naming dice in WEAVER++ involves the planning stages illustrated in Figure 1. First, there is the conceptual identification of the stimulus and the designation of a goal concept (e.g., TWO(X)). Second, the lemma of the corresponding word is retrieved (i.e., *two*), called response selection. A lemma is a representation of the syntactic properties of a word, crucial for its use in sentences. For example, the syntactic properties of cardinal numerals like *two* differ from those of other word classes and also from those of the ordinal numerals like *second* (Hurford, 1987). Third, the form of the word is encoded (i.e., a motor program for [tu:] is prepared), called response programming. Lemma retrieval and word-form encoding are discrete processes in that only the form of a selected lemma becomes activated and encoded. Finally, the name is articulated (“two”), called response execution. Perceived Arabic digits and written number words activate their lemma and output form in parallel. Consequently, digit and word naming may be achieved via a shallow form-to-form route from numeral form perception to word-form encoding (e.g., from the perceived orthographic forms TWO or 2 via word-form encoding to the articulatory program for [tu:]) or via an extra step of lemma retrieval (i.e., from TWO or 2 via the retrieval of the lemma *two* and the

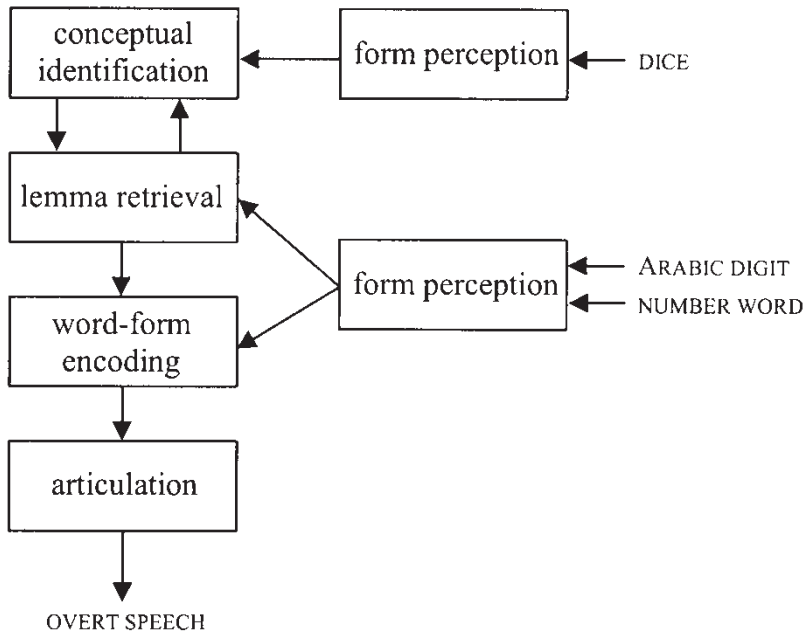

**Figure 1.** Functional architecture of naming dice, digits, and number words assumed by WEAV<sub>E</sub>AV<sub>E</sub> + +. Digits and words can be named via lemma retrieval or directly via word-form encoding.

subsequent encoding of the word form to [tu:]), roughly corresponding to what is traditionally called the semantic route in reading (Coltheart et al., 2001).

WEAV<sub>E</sub>AV<sub>E</sub> + + assumes that word planning includes retrieval from a lexical network by spreading activation. Figure 2 shows a fragment of WEAV<sub>E</sub>AV<sub>E</sub> + +’s lexical network. Perceiving dice activates the corresponding number concept nodes (e.g., TWO(X)) in the network. Activation then spreads through the network following a linear activation rule with a decay factor. Each node sends a proportion of its activation to the nodes it is connected to.

For example, TWO(X) sends activation to other concepts such as THREE(X) and also to its lemma node *two*. A selected lemma node activates the corresponding morpheme nodes (e.g., the lemma *two* activates the morpheme <two>), which activate the corresponding segments (/t/ and /u:/ for <two>) and syllable-based motor programs (i.e., [tu:]). I refer to Levelt et al. (1999) and Roelofs (1992, 1997, 2003) for an overview of the model and its motivation.

As extensively discussed in Roelofs (2003), Stroop-like effects occur in WEAV<sub>E</sub>AV<sub>E</sub> + + when the target and distractor activate nodes within

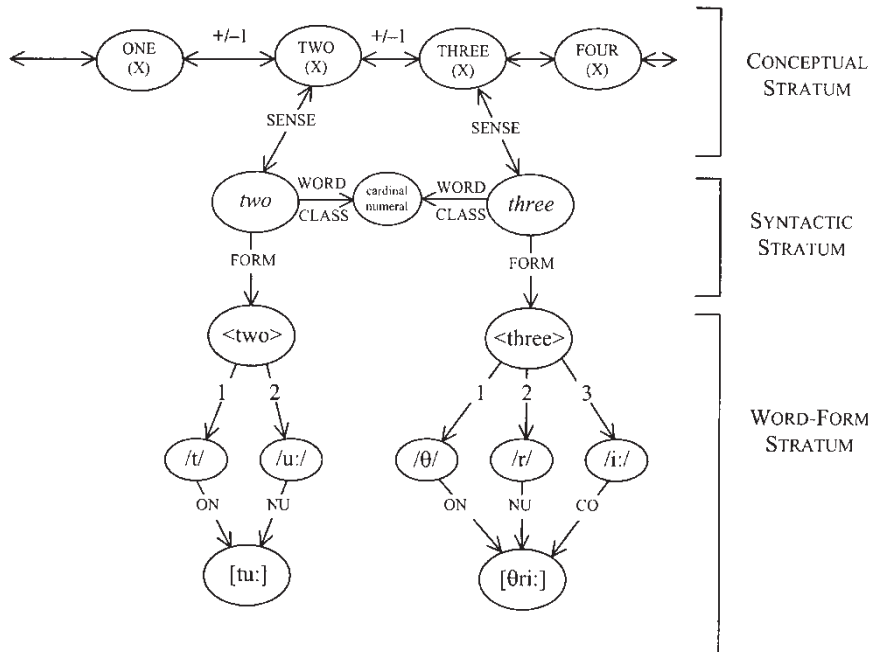

**Figure 2.** Fragment of the lexical network of WEAVER++ for numerals. Lexical concept nodes (e.g., TWO(X)) make up a conceptual stratum, lemma nodes (e.g., *two*) and syntactic property nodes (e.g., cardinal numeral) make up a syntactic stratum, and morpheme (e.g., <two>), segment (e.g., /t/), and syllable program nodes (e.g., [tu:]) make up a form stratum. The labels on the links indicate the relationship between the nodes (e.g., the link between <two> and /t/ is labelled 1 to indicate that /t/ is the first segment of <two>). The labels ON, NU, and CO indicate syllable onset, nucleus and coda, respectively.

the same network layer and the activation temporally overlaps, which happens when target and distractor are presented close together in time. Consequently, maximal interference in the model occurs around SOA = 0 ms (rather than at distractor-first SOAs, as predicted by other models; see Roelofs, 2003). Furthermore, interference increases with decreasing distractor preexposure and decreases with increasing distractor postexposure. That is, the model predicts that the SOA curve of interference has an “inverted-U” shape around SOA = 0 ms. Facilitation is predicted to be constant across distractor-first SOAs. Stroop-like effects are predicted for digit and number word distractors on dice naming, for digit distractors on word naming, and for word distractors on digit naming. In all these cases, the target and distractor activate representations in shared planning levels (see Figure 1). However, Stroop-like effects should not be observed for dice distractors in digit and word naming. Whereas dice naming is conceptually mediated in the model, digit and word naming

can be accomplished nonconceptually via word-form encoding only (see Figure 1). The latter route involves a shallow mapping of the orthographic code of the word (e.g., 2) onto the corresponding output word-form and articulatory program. Dice distractors activate lemmas, but this does not yield activation of the corresponding word forms because this depends on selection of the lemma in the model. Because the form of the name of dice distractors is not active, planning the target form in naming a written number word or Arabic digit remains unaffected by dice distractors. Thus, when digit/word naming is achieved without lemma retrieval, activation from dice distractors does not reach the planning levels involved in digit/word naming and distractor effects will be absent. To summarise, WEAVER + + predicts that digits and words should affect dice naming, but not vice versa. In contrast, digits should affect word naming and also vice versa, in line with the data of Reynvoet et al. (2002) but different from what Fias et al. (2001) observed. Furthermore, the model predicts that when interference occurs, maximal interference of distractors should be observed around  $SOA = 0$  ms, whereas facilitation should be constant across distractor-first SOAs.

## OVERVIEW OF THE EXPERIMENTS

The aim of Experiment 1 was to examine whether the interference and facilitation effects in dice naming and number word naming have the same time course as the classic picture-word and colour-word effects (Glaser & Dünghoff, 1984; Glaser & Glaser, 1982). Using Dutch participants, the experiment tested for number Stroop effects by means of separated (e.g., two dots next to the word DRIE, English THREE) rather than integrated dimensions (e.g., two times the word DRIE). Separation is required for the SOA manipulation. In the experiment, one group of participants named dice while ignoring number words and another group of participants named number words while ignoring dice. Experiment 2 tested the critical case of digit naming and word naming. Participants named digits while ignoring words or they named words while ignoring digits. Do digit naming and word naming with digit-word stimuli yield the asymmetrical effects and time courses observed for picture-word and colour-word stimuli, as predicted by the view that digit naming is like picture naming (Fias et al., 2001), or do digit-word stimuli yield symmetrical effects between tasks, as predicted by the view that digit naming is like word naming (WEAVER + +)? Experiment 3 tested the remaining combination of target and distractor types. Participants named dice while ignoring digits or they named digits while ignoring dice.

The stimuli of Experiments 1–3 were all within the subitizing range (1–4) and the physical size of the digit and word stimuli was approximately the

same. In Experiment 4, stimuli ranged from 0–9 (i.e., all digits were tested), as in the experiments of Fias et al. (2001), whereby participants named digits while ignoring words or they named words while ignoring digits. Finally, in Experiment 5, the digits had the same physical size as single letters of the number words, as in the experiments of Fias et al. (2001), to test for an effect of physical size. Participants named words while ignoring digits. All experiments examined interference and facilitation effects relative to the same control condition, which consisted of a grey patch of colour. In all experiments, the SOA was manipulated.

## EXPERIMENT 1

The intent of Experiment 1 was to examine whether Stroop-like effects from word distractors in dice naming and dice distractors in number word naming have the same time course as the picture-word and colour-word effects (Glaser & Dünghoff, 1984; Glaser & Glaser, 1982). The distractors were presented at seven different SOAs, namely at –300, –200, –100 ms preexposure (i.e., distractor-first SOAs), at 0 ms, or at 100, 200, and 300 ms postexposure (distractor-second SOAs). The targets and distractors were all within the subitizing range (1–4). Each task was performed by a different group of participants. Trials were blocked by SOA. One group of participants named dice while ignoring word distractors and another group of participants named the words while ignoring the dice distractors. To replicate the classic picture-word and colour-word asymmetries, word distractors should affect dice naming, but dice distractors should not affect word naming. Furthermore, interference should peak around SOA = 0 ms and facilitation should not vary with distractor-first SOAs, as observed for picture-word and colour-word stimuli (Glaser & Dünghoff, 1984; Glaser & Glaser, 1982, 1989).

### Method

*Participants.* All experiments were conducted with paid participants from the pool of the Max Planck Institute. All participants were young adult native speakers of Dutch. Each person only took part in one of the experiments reported in this paper. Experiments 1–3 were carried out each with a different group of 28 participants.

*Materials and design.* The stimuli in Experiment 1 were dice faces containing one, two, three, or four dots and the written number words *één* (one), *twee* (two), *drie* (three), and *vier* (four). The dice were 3.0 cm high and 3.0 cm wide (9.0 cm square). The words were presented in 36-point

lower case Arial font. The words were on average 1.2 cm high and 2.7 cm wide (3.2 cm square). The control condition consisted of a grey patch of colour of the size of an average written number word (used in all experiments). There were three independent variables. The first independent variable was *task* (dice naming, word naming), which was varied between participants. One half of the participants named the dice and the other half named the words. The second independent variable was *SOA* with seven levels: -300, -200, -100, 0, 100, 200, and 300 ms. *SOA* was varied within participants but between trial blocks. The order of *SOA* blocks was counterbalanced across participants using a Latin square. The third independent variable was *distractor*, which was tested within participants. With the basic stimulus set, all possible congruent, incongruent, and control pairings were created, making up the congruent, incongruent, and control conditions. To make the experiment as similar as possible to the classic *SOA* studies using colour-word and picture-word stimuli (Glaser & Dünghoff, 1984; Glaser & Glaser, 1982, 1989), the 4 congruent, 12 incongruent, and 4 control pairings occurred respectively 4, 2, and 2 times within an *SOA* block. This made the relative proportions of trials of the incongruent, congruent, and control conditions equal to those of the colour-word study of Glaser and Glaser (1982) and similar to those of the studies of Glaser and Dünghoff (1984) and Glaser and Glaser (1989). Target and distractor were presented next to each other on a computer screen. The left or right positions of the target relative to the distractor was randomly varied across trials. The positions were balanced over trials. Each particular target was tested once to the left and once to the right of a particular distractor. The participants received  $4 \text{ (targets)} \times 6 \text{ (distractors)} \times 2 \text{ (positions)} \times 7 \text{ (SOAs)} = 336 \text{ trials}$ .

*Procedure and apparatus.* The participants were tested individually. They were seated in front of a computer monitor (NEC Multisync) and a Sennheiser microphone connected to a voice key. The distance between participant and screen was approximately 50 cm. After the instructions, a block of 12 practice trials with  $\text{SOA} = 0 \text{ ms}$  was administered, which was followed by the 7 experimental *SOA* blocks. The structure of a trial was as follows. First, the participant saw a warning signal (an asterisk) for 500 ms. Next, the screen was cleared for 500 ms, followed by the display of the components of a number Stroop stimulus with the appropriate *SOA*. The stimuli were presented on a black background. The target stimuli were presented in yellow and the distractors in white. The written words and the dice faces were shown next to each other in the middle of the screen. Before the start of the next trial there was a blank interval of 500 ms. The total duration of a trial was 3 seconds. A Hermac computer controlled the stimulus presentation, voice key, and data collection.

*Analysis.* After each trial, the experimenter coded the response for errors. In all experiments, five types of incorrect responses were distinguished: wrong response word, wrong pronunciation of the word, a disfluency, triggering of the voice key by a non-speech sound, and failure to respond within 1500 ms after target presentation. Incorrect responses were excluded from the statistical analyses of the production latencies. The latencies and errors were submitted to analyses of variance (ANOVAs) with the crossed variables task, distractor, and SOA. Task was tested between participants and the other variables within participants. Interactions between distractor and SOA were further statistically explored through paired *t*-tests. In particular, pairwise comparisons tested for facilitation effects (i.e., differences between the congruent and control conditions) and for interference effects (i.e., differences between the incongruent and control conditions) for each SOA.

## Results and discussion

Tables 1 and 2 give the mean naming latencies, standard deviations, and error percentages for Experiment 1. The solid lines in Figure 3 show the congruency and incongruency effects relative to the control condition for dice naming and the dashed lines show the results for word naming. In the experiment, participants were presented with exactly the same dice and word stimuli, only the tasks differed between groups. Figure 3 reveals that

TABLE 1  
Mean naming latencies (*M*, in milliseconds), standard deviations (*SD*), and error percentages (*E%*) per distractor and SOA for Experiment 1: Dice naming with word distractor

<i>Distractor</i>	<i>SOA</i>							<i>Total</i>
	<i>-300</i>	<i>-200</i>	<i>-100</i>	<i>0</i>	<i>100</i>	<i>200</i>	<i>300</i>	
Incongruent								
<i>M</i>	543	558	600	597	579	528	512	559
<i>SD</i>	94	90	109	125	135	98	91	112
<i>E%</i>	1.8	2.4	2.1	6.9	3.0	2.1	2.1	2.9
Congruent								
<i>M</i>	524	524	556	541	530	523	513	530
<i>SD</i>	95	85	98	109	95	100	88	97
<i>E%</i>	0.9	0.9	2.2	1.3	1.8	2.7	0.5	1.5
Control								
<i>M</i>	545	544	571	546	544	531	514	542
<i>SD</i>	88	88	95	92	103	99	100	96
<i>E%</i>	2.7	0.0	2.7	1.8	3.6	0.0	0.9	1.7

TABLE 2  
 Mean naming latencies (M, in milliseconds), standard deviations (SD), and error percentages (E%) per distractor and SOA for Experiment 1: Word naming with dice distractor

<i>Distractor</i>	<i>SOA</i>							<i>Total</i>
	<i>-300</i>	<i>-200</i>	<i>-100</i>	<i>0</i>	<i>100</i>	<i>200</i>	<i>300</i>	
<i>Incongruent</i>								
<i>M</i>	483	481	485	467	479	474	458	475
<i>SD</i>	79	83	77	79	89	108	89	87
<i>E%</i>	3.3	4.8	3.0	2.4	1.8	2.7	2.4	2.9
<i>Congruent</i>								
<i>M</i>	462	457	472	469	474	470	462	467
<i>SD</i>	86	80	73	75	104	101	96	89
<i>E%</i>	4.5	3.6	1.3	1.8	3.2	2.2	3.6	2.9
<i>Control</i>								
<i>M</i>	477	463	476	475	485	469	473	474
<i>SD</i>	86	73	67	81	104	96	98	87
<i>E%</i>	5.4	0.9	1.8	3.6	2.7	4.5	3.6	3.2

there are different patterns of interference and facilitation depending on the task, dice naming with word distractors versus word naming with dice distractors. Whereas incongruent word distractors interfered with dice naming at SOAs around  $SOA = 0$  and 100 ms, there was no such effect from dice distractors on word naming. Furthermore, whereas congruent word distractors facilitated dice naming at the distractor-first SOAs, there was no such effect from dice distractors on word naming.

The asymmetry in interference and facilitation effects between tasks was confirmed in the analysis of variance. The analysis yielded a main effect of task,  $F(1, 26) = 10.15$ ,  $MSE = 76042$ ,  $p < .004$  (the mean latencies for dice naming and word naming were, respectively, 547 and 472 ms). There were effects of distractor,  $F(2, 52) = 36.09$ ,  $MSE = 476$ ,  $p < .001$ , and SOA,  $F(6, 156) = 6.35$ ,  $MSE = 2085$ ,  $p < .001$ . Furthermore, the effects of distractor and of SOA varied between tasks, respectively  $F(2, 52) = 12.90$ ,  $MSE = 476$ ,  $p < .001$ , and  $F(6, 156) = 3.31$ ,  $MSE = 6896$ ,  $p < .004$ . In addition, there was a triple interaction of task, distractor, and SOA,  $F(12, 312) = 4.67$ ,  $MSE = 337$ ,  $p < .001$ . Tables 1 and 2 show that the error rates did not differ much among the conditions. This was confirmed by the statistical analysis of the errors, which yielded no significant effects (all  $ps > .05$ ).

The statistical analysis of the naming latencies in the dice naming task yielded main effects of SOA,  $F(6, 78) = 7.28$ ,  $MSE = 2605$ ,  $p < .001$ , and distractor,  $F(2, 26) = 28.09$ ,  $MSE = 765$ ,  $p < .001$ . Furthermore, SOA and distractor interacted,  $F(12, 156) = 6.33$ ,  $MSE = 368$ ,  $p < .001$ . Pairwise

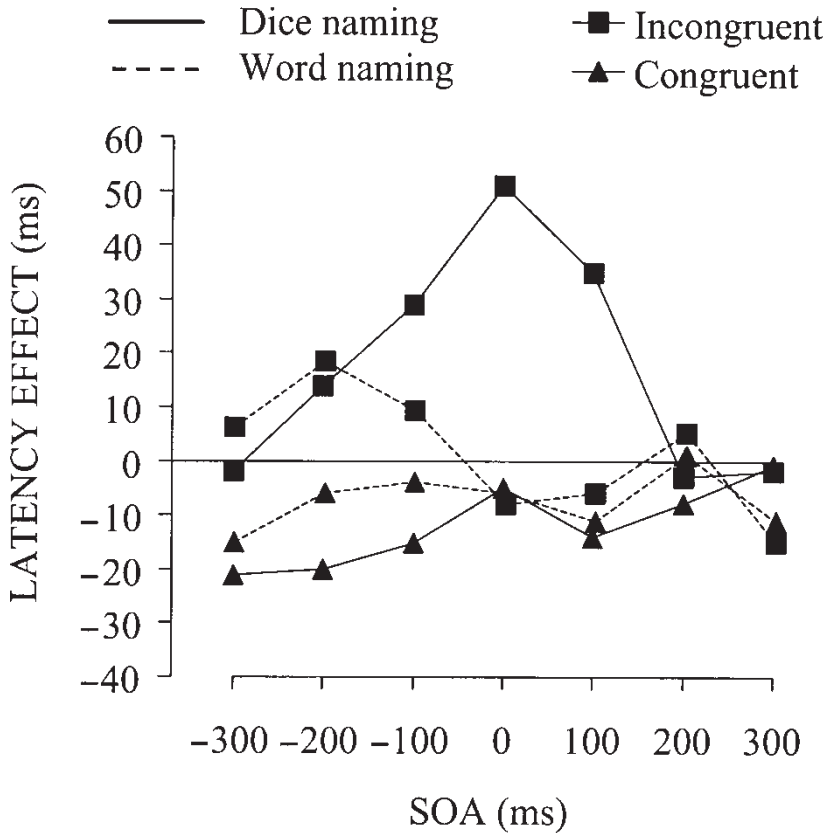

**Figure 3.** Time course of the number Stroop effects observed in Experiment 1. Positive effects indicate interference and negative effects indicate facilitation relative to the control condition.

comparisons between the congruent and control conditions per SOA revealed that the facilitation was significant at the SOAs of  $-300$  and  $-200$  ms ( $ps < .05$ ) but not at the later SOAs ( $ps > .05$ ). Pairwise comparisons between the incongruent and control conditions per SOA revealed that the interference was significant at the SOAs of  $-200$ ,  $-100$ ,  $0$  and  $100$  ms ( $ps < .05$ ) but not at the other SOAs ( $ps > .05$ ).

The statistical analysis of the naming latencies in the word naming task yielded a main effect of distractor,  $F(2, 26) = 9.83$ ,  $MSE = 188$ ,  $p < .001$ , but not of SOA,  $F(6, 78) < 1$ ,  $MSE = 1564$ ,  $p > .62$ . Furthermore, SOA and distractor interacted,  $F(12, 156) = 2.26$ ,  $MSE = 305$ ,  $p < .012$ . Further analyses revealed that the overall 7-ms facilitation effect of congruent distractors relative to the control condition was significant ( $p < .004$ ), but

the 1-ms effect of incongruent distractors not. Pairwise comparisons between the congruent and control conditions per SOA yielded no significant results (all  $ps > .05$ ). Pairwise comparisons between the incongruent and control conditions per SOA revealed that the interference was significant at the SOA of  $-200$  ( $p < .006$ ) but not at the other SOAs ( $p > .05$ ).

Thus, the patterns of interference and facilitation depend on the task, dice naming with word distractors versus word naming with dice distractors. Whereas congruent word distractors facilitated dice naming at the SOAs of  $-300$  and  $-200$  ms, there was no such effect for dice distractors on word naming. Also, whereas incongruent word distractors interfered with dice naming at the SOAs of  $-200$ ,  $-100$ ,  $0$ , and  $100$  ms, interference for dice distractors on word naming was only observed at the SOA of  $-200$  ms.

These asymmetrical effects between tasks agree with the classic asymmetry observed with picture-word and colour-word stimuli (Glaser & Dünghoff, 1984; Glaser & Glaser, 1982, 1989). Furthermore, the findings suggest that, as with picture-word and colour-word stimuli, the asymmetry is not due to a different relative speed of processing of dice and number words, but that it has a functional basis. In the control conditions, dice naming was some 75 ms slower than word naming. Compensating for this difference by presenting the dice distractors 100, 200, or 300 ms before the target words still yielded asymmetrical patterns of interference between dice naming and word naming. As observed for picture-word and colour-word stimuli (Glaser & Dünghoff, 1984; Glaser & Glaser, 1982, 1989), interference peaked around  $SOA = 0$  ms and facilitation did not vary much with distractor-first SOAs.

## EXPERIMENT 2

The second experiment tested the predictions derived from the different positions on the planning levels involved in digit naming. If digit naming involves the same word planning levels as dice naming, then word distractors should affect digit naming in the same way as they affected dice naming in Experiment 1, but digit distractors should not affect word naming (in the same way as dice did not affect word naming in Experiment 1). However, if digit naming involves the same word planning levels as word naming, digit-word effects should be like word-word effects (Glaser & Glaser, 1989) with digits affecting word naming and words affecting digit naming, whereby the magnitude of the effects should be the same for the two tasks. In the experiment, one group of participants named Arabic digits and ignored number word distractors, and another group of participants named number words and ignored Arabic digit distractors.

Comparable effects from distractor digits and words would suggest that digit-word interference is like word-word interference rather than like picture-word interference, contrary to the claim by Fias et al. (2001). Again, to replicate the classic picture-word, colour-word, and word-word findings (Glaser & Dünghoff, 1984; Glaser & Glaser, 1982, 1989) maximal interference should be observed around  $SOA = 0$  ms, whereas the facilitation should not vary with distractor preexposure.

## Method

This was the same as in Experiment 1, except that the participants were now asked to name Arabic digits or number words, depending on the task. The digits were presented in 48-point lower case Arial font. They were on average 1.4 cm wide and 2.3 cm high (3.2 cm square). As in Experiment 1, the words were presented in 36-point lower case Arial font. They were on average 1.2 cm high and 2.7 cm wide (3.2 cm square).

## Results and discussion

Tables 3 and 4 give the mean naming latencies, standard deviations, and error percentages for digit and word naming in Experiment 2. The solid lines in Figure 4 show the congruency and incongruency effects relative to the control condition for digit naming with word distractors and the dashed lines give the results for word naming with digit distractors. Unlike

TABLE 3  
Mean naming latencies ( $M$ , in milliseconds), standard deviations ( $SD$ ), and error percentages ( $E\%$ ) per distractor and  $SOA$  for Experiment 2: Digit naming with word distractor

<i>Distractor</i>	<i>SOA</i>							<i>Total</i>
	<i>-300</i>	<i>-200</i>	<i>-100</i>	<i>0</i>	<i>100</i>	<i>200</i>	<i>300</i>	
Incongruent								
<i>M</i>	429	435	456	450	429	422	413	433
<i>SD</i>	70	76	72	89	80	75	75	78
<i>E%</i>	3.0	4.2	2.1	6.9	3.3	3.9	0.9	3.5
Congruent								
<i>M</i>	409	404	424	428	421	426	413	418
<i>SD</i>	75	76	66	62	74	79	77	73
<i>E%</i>	0.9	0.0	1.4	1.8	0.9	1.4	0.5	1.0
Control								
<i>M</i>	428	424	436	434	431	422	416	427
<i>SD</i>	63	62	61	73	77	77	90	73
<i>E%</i>	0.9	0.9	2.7	1.8	0.0	0.0	0.0	0.9

TABLE 4  
 Mean naming latencies (M, in milliseconds), standard deviations (SD), and error percentages (E%) per distractor and SOA for Experiment 2: Word naming with digit distractor

<i>Distractor</i>	<i>SOA</i>							<i>Total</i>
	<i>-300</i>	<i>-200</i>	<i>-100</i>	<i>0</i>	<i>100</i>	<i>200</i>	<i>300</i>	
<b>Incongruent</b>								
<i>M</i>	478	471	481	487	467	468	450	472
<i>SD</i>	83	70	68	97	71	104	81	84
<i>E%</i>	2.4	1.8	2.4	2.7	2.7	2.4	1.5	2.3
<b>Congruent</b>								
<i>M</i>	443	437	443	459	462	467	447	451
<i>SD</i>	69	71	63	72	69	87	71	73
<i>E%</i>	0.9	0.9	1.8	2.7	1.8	0.9	0.9	1.4
<b>Control</b>								
<i>M</i>	465	461	466	464	462	459	453	462
<i>SD</i>	65	67	66	63	72	92	88	74
<i>E%</i>	0.0	0.9	0.0	0.0	4.5	4.5	1.8	1.7

Experiment 1, the patterns of interference and facilitation were equivalent for the two tasks. Facilitation from congruent distractors was obtained at the distractor-first SOAs in both tasks and interference from incongruent distractors was observed at the SOAs around SOA = 0 ms in both tasks.

The symmetry in interference and facilitation effects between tasks was confirmed in the analysis of variance. The analysis yielded a main effect of task (the mean latencies for digit naming and word naming were, respectively, 426 and 462 ms),  $F(1, 26) = 5.18$ ,  $MSE = 36734$ ,  $p < .03$ , distractor,  $F(2, 52) = 56.56$ ,  $MSE = 287$ ,  $p < .001$ , and SOA,  $F(6, 156) = 3.35$ ,  $MSE = 1390$ ,  $p < .004$ . Distractor and SOA interacted,  $F(12, 312) = 7.69$ ,  $MSE = 243$ ,  $p < .001$ . However, the effects of distractor and of SOA did not vary with task,  $F(2, 52) = 1.30$ ,  $MSE = 287$ ,  $p > .28$ , and  $F(6, 156) < 1$ ,  $MSE = 1390$ ,  $p > .79$ . There was no interaction of task, distractor, and SOA,  $F(12, 312) < 1$ ,  $MSE = 243$ ,  $p > .94$ . Pairwise comparisons between the congruent and control conditions per SOA revealed that there were significant differences at the SOAs of  $-300$ ,  $-200$ , and  $-100$  ms (all  $ps < .05$ ) but not at the other SOAs ( $ps > .05$ ). Pairwise comparisons between the incongruent and control conditions per SOA revealed that the interference was significant at the SOAs of  $-100$  and  $0$  ms ( $ps < .05$ ) but not at the other SOAs ( $p > .05$ ). Tables 3 and 4 show that the error rates did not differ much among the conditions. This was confirmed by the statistical analyses of the errors, which yielded no significant effects (all  $ps > .05$ ).

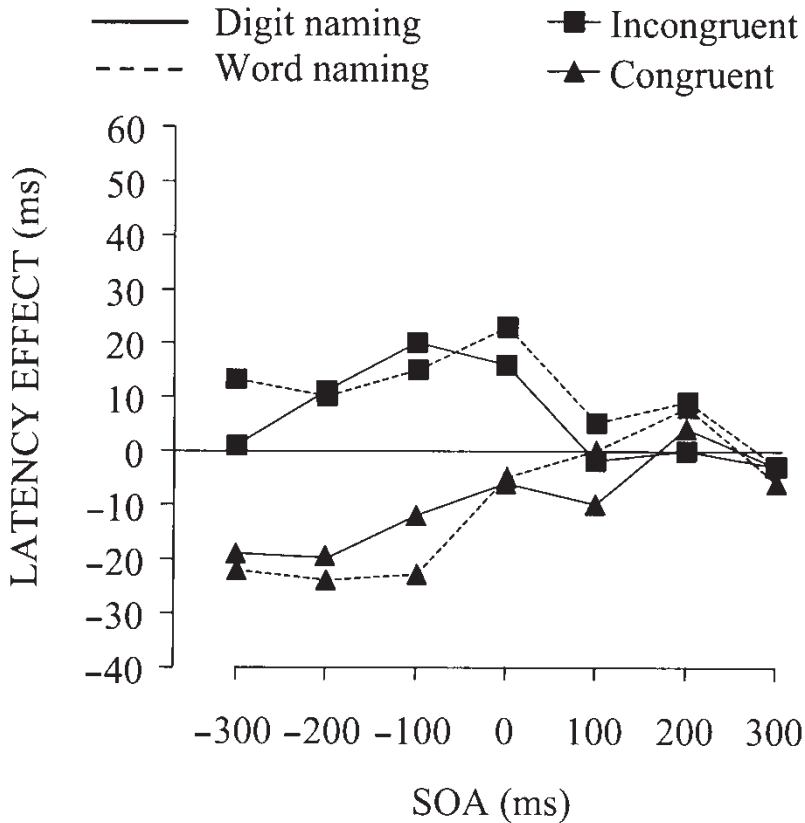

**Figure 4.** Time course of the number Stroop effects observed in Experiment 2. Positive effects indicate interference and negative effects indicate facilitation relative to the control condition.

In agreement with the masked-priming results of Reynvoet et al. (2002) but different from what Fias et al. (2001) observed, the effects were symmetrical between tasks. The symmetrical effects for digit naming with digit-word stimuli and word naming with digit-word stimuli suggest that digit naming is like word naming rather than like dice naming. Again, maximal interference was obtained around SOA = 0 ms and facilitation was constant across distractor-first SOAs, in agreement with the classic results for word-word interference (Glaser & Glaser, 1989).

### EXPERIMENT 3

The aim of the third experiment was to test the remaining combination of targets and distractors. The experiment tested for the impact of digit

distractors on dice naming and for the effect of dice distractors on digit naming. To obtain a consistent set of results across experiments, digit distractors should affect dice naming, but dice distractors should not affect digit naming. Maximal interference should be observed around  $SOA = 0$  ms, whereas facilitation should be constant across distractor-first SOAs.

## Method

This was the same as in Experiment 1, except that the participants were now asked to name dice or digits depending on the task.

## Results and discussion

Tables 5 and 6 give the mean naming latencies, standard deviations, and error percentages for Experiment 3. The solid lines in Figure 5 show the congruency and incongruency effects relative to the control condition for dice naming and the dashed lines show the results for digit naming. Whereas congruent digit distractors facilitated dice naming at the SOAs around  $SOA = 0$  ms, there was no such effect for dice distractors on digit naming. Also, whereas incongruent digit distractors interfered with dice naming at the SOAs around  $SOA = 0$  ms, no such interference was observed for dice distractors on digit naming.

TABLE 5  
Mean naming latencies (*M*, in milliseconds), standard deviations (*SD*), and error percentages (*E%*) per distractor and *SOA* for Experiment 3: Dice naming with digit distractor

<i>Distractor</i>	<i>SOA</i>							<i>Total</i>
	<i>-300</i>	<i>-200</i>	<i>-100</i>	<i>0</i>	<i>100</i>	<i>200</i>	<i>300</i>	
Incongruent								
<i>M</i>	535	563	560	575	564	503	492	542
<i>SD</i>	98	86	79	87	112	92	92	97
<i>E%</i>	2.7	1.8	0.9	5.1	4.8	3.9	1.5	2.9
Congruent								
<i>M</i>	517	544	528	534	529	502	487	520
<i>SD</i>	101	86	87	89	81	88	82	90
<i>E%</i>	0.9	1.8	2.2	2.2	0.5	2.2	1.3	1.6
Control								
<i>M</i>	531	555	547	549	539	508	492	532
<i>SD</i>	75	79	73	84	93	87	71	83
<i>E%</i>	0.0	2.7	0.0	0.9	0.9	1.8	1.8	1.2

TABLE 6  
 Mean naming latencies (M, in milliseconds), standard deviations (SD), and error percentages (E%) per distractor and SOA for Experiment 3: Digit naming with dice distractor

Distractor	SOA						Total	
	-300	-200	-100	0	100	200		300
Incongruent								
<i>M</i>	450	464	468	457	465	449	455	458
<i>SD</i>	100	108	110	104	123	107	128	112
<i>E%</i>	2.7	3.3	2.1	0.6	2.1	0.6	0.9	1.7
Congruent								
<i>M</i>	438	440	453	457	462	450	448	450
<i>SD</i>	99	107	99	118	108	106	111	107
<i>E%</i>	1.8	2.7	1.8	1.8	2.2	0.9	1.8	1.9
Control								
<i>M</i>	450	451	453	456	460	451	461	455
<i>SD</i>	95	104	91	123	95	99	130	106
<i>E%</i>	0.9	1.8	3.6	0.9	1.8	2.7	0.0	1.7

The asymmetry in interference and facilitation effects between tasks was confirmed in the analysis of variance. The analysis yielded a main effect of task,  $F(1, 26) = 8.50$ ,  $MSE = 100932$ ,  $p < .007$  (the mean latencies for dice naming and digit naming were, respectively, 533 and 455 ms). There were effects of distractor,  $F(2, 52) = 34.53$ ,  $MSE = 320$ ,  $p < .001$ , and SOA,  $F(6, 156) = 8.42$ ,  $MSE = 1823$ ,  $p < .001$ . Distractor and SOA interacted,  $F(12, 312) = 1.87$ ,  $MSE = 375$ ,  $p < .04$ . Most importantly, the effects of distractor and of SOA varied with task, respectively  $F(2, 52) = 6.81$ ,  $MSE = 320$ ,  $p < .002$ , and  $F(6, 156) = 6.61$ ,  $MSE = 1823$ ,  $p < .001$ . Furthermore, there was a triple interaction of task, distractor, and SOA,  $F(12, 312) = 1.90$ ,  $MSE = 375$ ,  $p < .04$ . Tables 5 and 6 show that the error rates did not differ much among the conditions. This was confirmed by the statistical analysis of the errors, which yielded no significant effects (all  $ps > .05$ ).

The statistical analysis of the naming latencies for dice naming yielded main effects of distractor,  $F(2, 26) = 28.21$ ,  $MSE = 408$ ,  $p < .001$ , and SOA,  $F(6, 78) = 12.03$ ,  $MSE = 2188$ ,  $p < .001$ . Furthermore, SOA and distractor interacted,  $F(12, 156) = 2.74$ ,  $MSE = 338$ ,  $p < .002$ . Pairwise comparisons between the congruent and control conditions per SOA revealed that there were significant differences at the SOAs of -100, 0, and 100 ms (all  $ps < .05$ ) but not at the other SOAs ( $ps > .05$ ). Pairwise comparisons between the incongruent and control conditions per SOA

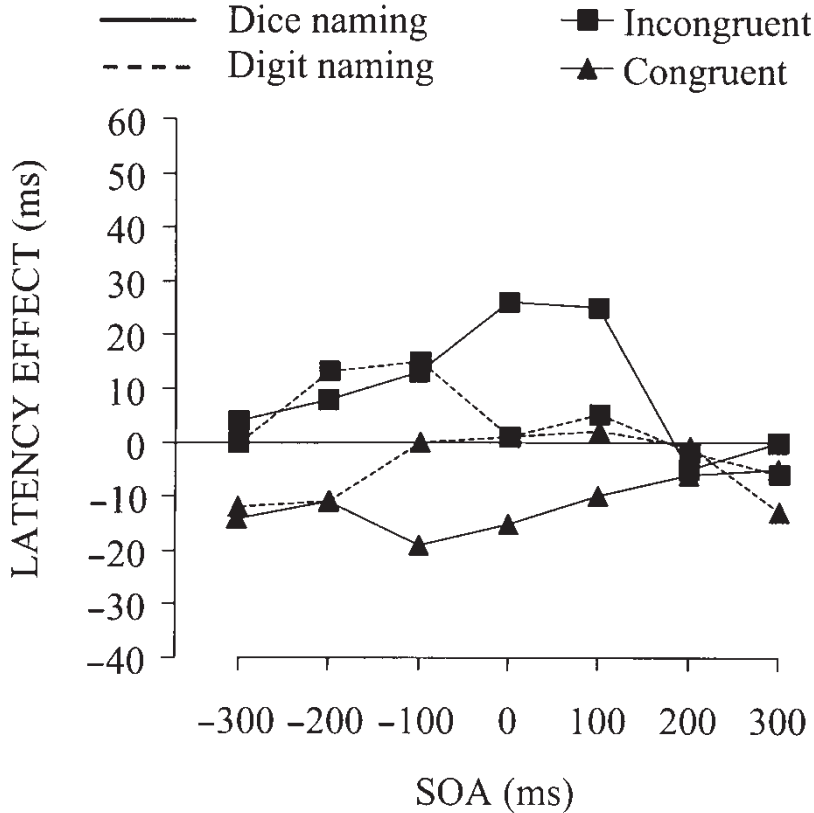

**Figure 5.** Time course of the number Stroop effects observed in Experiment 3. Positive effects indicate interference and negative effects indicate facilitation relative to the control condition.

revealed that the interference was significant at the SOAs of 0 and 100 ms ( $ps < .05$ ) but not at the other SOAs ( $ps > .05$ ).

The statistical analysis of the naming latencies for digit naming yielded only a main effect of distractor,  $F(2, 26) = 7.47$ ,  $MSE = 233$ ,  $p < .003$ . There was no effect of SOA,  $F(6, 78) < 1$ ,  $MSE = 1458$ ,  $p > .62$ . Furthermore, SOA and distractor did not interact,  $F(12, 156) < 1$ ,  $MSE = 411$ ,  $p > .52$ . Further analyses revealed that the overall 5-ms effect of congruent distractors relative to the control condition was significant ( $p < .03$ ), but the overall 3-ms effect of incongruent distractors not ( $p > .15$ ).

The results of this third experiment generally agree with those from Experiments 1 and 2. As expected on the basis of the earlier results, digit distractors affected dice naming, but dice distractors did not much affect digit naming. Maximal interference was observed around SOA = 0 ms and

facilitation was roughly constant across SOAs (up to SOA = 100 ms). Yet, although there is general agreement between the results of Experiments 1 and 3, there are also some noticeable differences. For example, the size of the interference effect at SOA = 0 ms in dice naming differed between experiments. Also, the facilitation for dice naming existed significantly at SOAs of -100, 0, and 100 ms in Experiment 3, whereas it only existed significantly at the SOAs of -200 and -300 ms in Experiment 1. Still, if we focus on the patterns rather than the individual data points, the results are similar. Both experiments showed the asymmetry in effects between the dice naming task, on the one hand, and the word naming task (Experiment 1) and digit naming task (Experiment 3), on the other. Importantly, the asymmetry in effects is not obtained between the word naming and digit naming tasks themselves (Experiment 2).

#### EXPERIMENT 4

The outcomes of Experiments 1–3 suggest that Arabic digits are named like words rather than like pictures, different from what Fias et al. (2001) claimed. However, whereas the results of the present Experiment 2 agree with the masked-priming results of Reynvoet et al. (2002), they differ from the results of Fias et al. Whereas Fias et al. observed that words affected digit naming but not vice versa, Experiment 2 showed symmetrical effects between tasks. What is the cause of this difference in effects between studies? One of the differences between the present experiments and those of Fias et al. is that the present Experiments 1–3 used stimuli in the subitizing range (1–4) whereas the stimuli ranged from 0–9 in the experiments of Fias et al. To test whether the present findings are only valid for the subitizing range or whether they can be generalised to all digits, Experiment 4 replicated Experiment 2 with stimuli ranging from 0–9, as in the experiments of Fias et al. One group of participants named digits while ignoring words and another group of participants named words while ignoring digits.

#### Method

This was the same as in Experiment 2, except that the stimuli ranged from 0–9. The digits and words were presented in white on a black background. Furthermore, as in the experiments of Fias et al. (2001), each condition now occurred equally often. Each target occurred 12 times per SOA, 4 times randomly paired with an incongruent distractor, 4 times paired with a congruent distractor, and 4 times with a control distractor. On half the trials of each distractor condition the target appeared to the left of the distractor on the screen and on the other half of the trials the target appeared to the right of the distractor. Each distractor occurred 8 times per

SOA, 4 times in an incongruent pairing and 4 times in a congruent pairing. In order to make the total number of trials in the experiment comparable to the number of trials of Experiment 2, only three SOAs were tested:  $-100$ ,  $0$ , and  $100$  ms. A participant received  $10$  (targets)  $\times$   $12$  (distractors)  $\times$   $3$  (SOAs) =  $360$  trials. The experiment was carried out with a new group of  $30$  participants.

## Results and discussion

Tables 7 and 8 give the mean naming latencies, standard deviations, and error percentages for digit and word naming in Experiment 4. The results are similar to those of Experiment 2. Interference from incongruent distractors was observed at the SOAs of  $-100$  and  $0$  ms and the effect sizes did not differ between tasks. At  $SOA = -100$  ms,  $29$  ms interference was obtained in digit naming and  $31$  ms in word naming; at  $SOA = 0$  ms,  $29$  ms interference was obtained in digit naming and  $23$  ms in word naming. Different from Experiment 2, congruent distractors did not yield facilitation except for an effect of  $14$  ms at  $SOA = -100$  ms in word naming. The interference effect of  $29$  ms for digit naming at  $SOA = 0$  ms is close in magnitude to the interference obtained by Fias et al. (2001), who obtained an effect of about  $35$  ms at  $SOA = 0$  ms (the only SOA they tested). Similarly, Fias et al. (2001) obtained no facilitation from congruent distractors relative to control. However, the present experiment obtained

TABLE 7  
Mean naming latencies ( $M$ , in milliseconds), standard deviations ( $SD$ ), and error percentages ( $E\%$ ) per distractor and SOA for Experiment 4: Digit naming with word distractor

<i>Distractor</i>	<i>SOA</i>			<i>Total</i>
	<i>-100</i>	<i>0</i>	<i>100</i>	
Incongruent				
<i>M</i>	469	482	440	464
<i>SD</i>	112	121	103	113
<i>E%</i>	3.8	3.8	3.8	3.8
Congruent				
<i>M</i>	438	454	451	448
<i>SD</i>	101	100	98	100
<i>E%</i>	2.8	3.0	5.3	3.7
Control				
<i>M</i>	440	453	449	447
<i>SD</i>	105	96	94	98
<i>E%</i>	4.7	3.2	4.7	4.0

TABLE 8  
 Mean naming latencies (M, in milliseconds), standard deviations (SD), and error percentages (E%) per distractor and SOA for Experiment 4: Word naming with digit distractor

<i>Distractor</i>	<i>SOA</i>			<i>Total</i>
	<i>-100</i>	<i>0</i>	<i>100</i>	
Incongruent				
<i>M</i>	500	495	482	492
<i>SD</i>	139	144	138	141
<i>E%</i>	3.5	4.8	4.3	4.2
Congruent				
<i>M</i>	455	477	474	468
<i>SD</i>	109	133	130	125
<i>E%</i>	3.3	4.7	4.8	4.3
Control				
<i>M</i>	469	472	475	472
<i>SD</i>	122	127	135	128
<i>E%</i>	4.8	6.8	3.5	5.1

interference both in digit naming (29 ms at SOA = 0 ms) and in word naming (23 ms at SOA = 0 ms), exactly as in Experiment 2, whereas Fias et al. (2001) obtained no interference effect for word naming.

The statistical analysis of the naming latencies yielded no main effects of task (the mean latencies for digit naming and word naming were, respectively, 453 and 478 ms),  $F(1, 28) < 1$ , and SOA,  $F(2, 56) = 1.80$ ,  $MSE = 1947$ ,  $p > .17$ , but there was an effect of distractor,  $F(2, 56) = 29.02$ ,  $MSE = 418$ ,  $p < .001$ . Distractor and SOA interacted,  $F(4, 112) = 14.25$ ,  $MSE = 237$ ,  $p < .001$ . The effects of distractor and of SOA did not vary with task,  $F(2, 56) = 1.06$ ,  $MSE = 418$ ,  $p > .35$  and  $F(2, 56) < 1$ . However, there was an interaction of task, distractor, and SOA,  $F(4, 112) = 2.90$ ,  $MSE = 237$ ,  $p < .025$ . Pairwise comparisons revealed that the triple interaction reflected the fact that facilitation (14 ms) was obtained at SOA = -100 ms in word naming but not in digit naming. Tables 7 and 8 show that the error rates did not differ much among the conditions. This was confirmed by the statistical analysis of the errors, which yielded no significant results (all  $ps > .05$ ).

The statistical analysis of the naming latencies for digit naming with word distractors yielded main effects of distractor,  $F(2, 28) = 10.66$ ,  $MSE = 408$ ,  $p < .001$ , but not of SOA,  $F(2, 28) = 1.99$ ,  $MSE = 1950$ ,  $p > .15$ . Furthermore, SOA and distractor interacted,  $F(4, 56) = 16.82$ ,  $MSE = 156$ ,  $p < .001$ . Pairwise comparisons between the congruent and control

conditions per SOA revealed that there were no significant differences (all  $ps > .05$ ). Pairwise comparisons between the incongruent and control conditions per SOA revealed that the interference was significant at the SOAs of  $-100$  and  $0$  ms ( $ps < .05$ ) but not at the other SOA ( $p > .05$ ).

The statistical analysis of the naming latencies for word naming with digit distractors yielded a main effect of distractor,  $F(2, 28) = 19.20$ ,  $MSE = 430$ ,  $p < .001$ , but not of SOA,  $F(2, 28) < 1$ . Furthermore, SOA and distractor interacted,  $F(4, 56) = 4.53$ ,  $MSE = 319$ ,  $p < .003$ . Pairwise comparisons between the congruent and control conditions per SOA revealed that there was a significant difference at the SOA of  $-100$  ms ( $p < .05$ ) but not at the other SOAs ( $ps > .05$ ). Pairwise comparisons between the incongruent and control conditions per SOA revealed that the interference was significant at the SOAs of  $-100$  and  $0$  ms ( $ps < .01$ ) but not at the other SOA ( $p > .05$ ).

To conclude, the present experiment replicated the results of Experiment 2 with stimuli ranging from 0–9 rather than from 1–4, except that facilitation was not obtained at the distractor-first SOA in digit naming but only in word naming. However, at the SOA =  $0$  ms, where Fias et al. (2001) obtained the asymmetrical effects between tasks, digit distractors affected word naming and word distractors affected digit naming to the same extent, both in Experiment 2 (with stimuli in the range of 1–4) and in Experiment 4 (with stimuli in the range of 0–9). Thus, the difference between the results of the present experiments and those of Fias et al. cannot be due to the range of stimuli tested. The present results hold for all digits in the Dutch language.

## EXPERIMENT 5

Another difference between the present experiments and those of Fias et al. is the relative physical size of the digits and words. In Experiments 1–4, the digits and the words had approximately the same physical size, whereas in the experiments of Fias et al. (2001) the digits had the same size as a single letter of a corresponding word. To test for an effect of distractor size, the digits in Experiment 5 had the same font size as the letters of the number words, as in the experiments of Fias et al. A new group of 15 participants named words while ignoring digits. The SOAs were  $-100$ ,  $0$ , and  $100$  ms.

### Method

This was the same as in Experiment 4, except that the digits had the same size as a single letter of the number words. Both the digits and the letters of the words were presented in 36-point lower case Arial font in white on a black background. Only word naming, and not digit naming, was tested.

## Results and discussion

Table 9 gives the mean naming latencies, standard deviations, and error percentages for word naming in Experiment 5. At  $SOA = -100$  ms, 37 ms interference was obtained, but at  $SOA = 0$  ms there was no effect (4 ms). The interference effect at the distractor-first SOA corresponds to the interference effects obtained in Experiments 2 and 4, and it corresponds to what Reynvoet et al. (2002) obtained using an SOA of  $-114$  ms in their masked priming study, whereas the absence of interference at  $SOA = 0$  ms corresponds to what Fias et al. (2001) observed.

The statistical analysis of the naming latencies yielded a main effect of distractor,  $F(2, 28) = 19.17$ ,  $MSE = 204$ ,  $p < .001$ , but not of SOA,  $F(2, 28) < 1$ . Furthermore, SOA and distractor interacted,  $F(4, 56) = 15.19$ ,  $MSE = 161$ ,  $p < .001$ . Pairwise comparisons between the congruent and control conditions per SOA revealed that there were no significant differences. Pairwise comparisons between the incongruent and control conditions per SOA revealed that the interference was significant at the SOA of  $-100$  ( $p < .001$ ) but not at the other SOAs ( $ps > .05$ ). The statistical analyses of the errors yielded no significant effects (all  $ps > .05$ ).

These results suggest that the difference in physical size of the distractors caused the difference between the results of the present experiments and those of Fias et al. (2001). When the size of a digit is the same as that of a single letter, word naming is not affected by digit

TABLE 9  
Mean naming latencies (M, in milliseconds), standard deviations (SD), and error percentages (E%) per distractor and SOA for Experiment 5: Word naming with digit distractor

Distractor	SOA			Total
	-100	0	100	
Incongruent				
<i>M</i>	470	443	437	450
<i>SD</i>	99	91	94	96
<i>E%</i>	4.5	2.2	4.0	3.6
Congruent				
<i>M</i>	424	435	437	432
<i>SD</i>	89	82	99	90
<i>E%</i>	3.2	3.2	3.2	3.2
Control				
<i>M</i>	433	439	436	436
<i>SD</i>	77	90	99	89
<i>E%</i>	2.3	2.0	3.5	2.6

distractors at  $SOA = 0$  ms but it is affected at  $SOA = -100$  ms. The size of the interference at the latter SOA is the same as the interference effects in the previous experiments obtained for digits of large physical size. Thus, digits of small physical size do interfere with word naming, except that the effects only occur with distractor preexposure, in agreement with Reynvoet et al. (2002).

### WEAVER + + SIMULATIONS

In this section, I report the results of computer simulations that showed that WEAVER + + captures the key empirical findings concerning the asymmetrical and symmetrical number Stroop effects between tasks. The present simulations used procedures and parameter values that were exactly the same as in earlier simulations of the model (Roelofs, 1992, 1997, 2003). The numerals in the simulations were *one*, *two*, *three*, and *four*. Including more numerals gave equivalent results. A fragment of the network used in the simulations is illustrated in Figure 2. Two small parameter adjustments were made to fine-tune the present fits. The response threshold was set to 1.6 in the simulations of Experiments 1 and 3, and to 4.0 in the simulations of Experiment 2, and the distractor duration was set to 75 ms in both cases. Figure 6 gives the results of the computer simulations.

The upper panel of Figure 6 displays the results of the simulations of Experiments 1 and 3. The figure shows how the latencies of spoken numeral planning in the model are affected by congruent and incongruent distractors relative to no distractor. The solid lines give the results for dice naming with digit/word distractors and the dashed lines give the results for digit/word naming with dice distractors. Digit/word distractors yielded interference and facilitation in dice naming, but dice distractors did not have an effect on digit/word naming. There was no “reverse” number Stroop effect. This asymmetry in effects corresponds to what was empirically observed. Furthermore, the peak of the interference was around  $SOA = 0$  ms, as empirically observed.

Why are there no effects of dice distractors on digit/word naming in the model? This is because digit/word naming was accomplished by a nonconceptual mapping of the orthographic code of the word or digit onto the corresponding output word-form and articulatory program (see Figure 1). The model distinguishes between activation and selection. Lemmas may be activated by number concepts for dice, but these lemmas are not selected because this requires that the task is dice naming (which it was not). Because only selected lemmas activate the corresponding forms, dice distractors will not activate their forms. Consequently, planning forms for digits and words is unaffected by dice distractors.

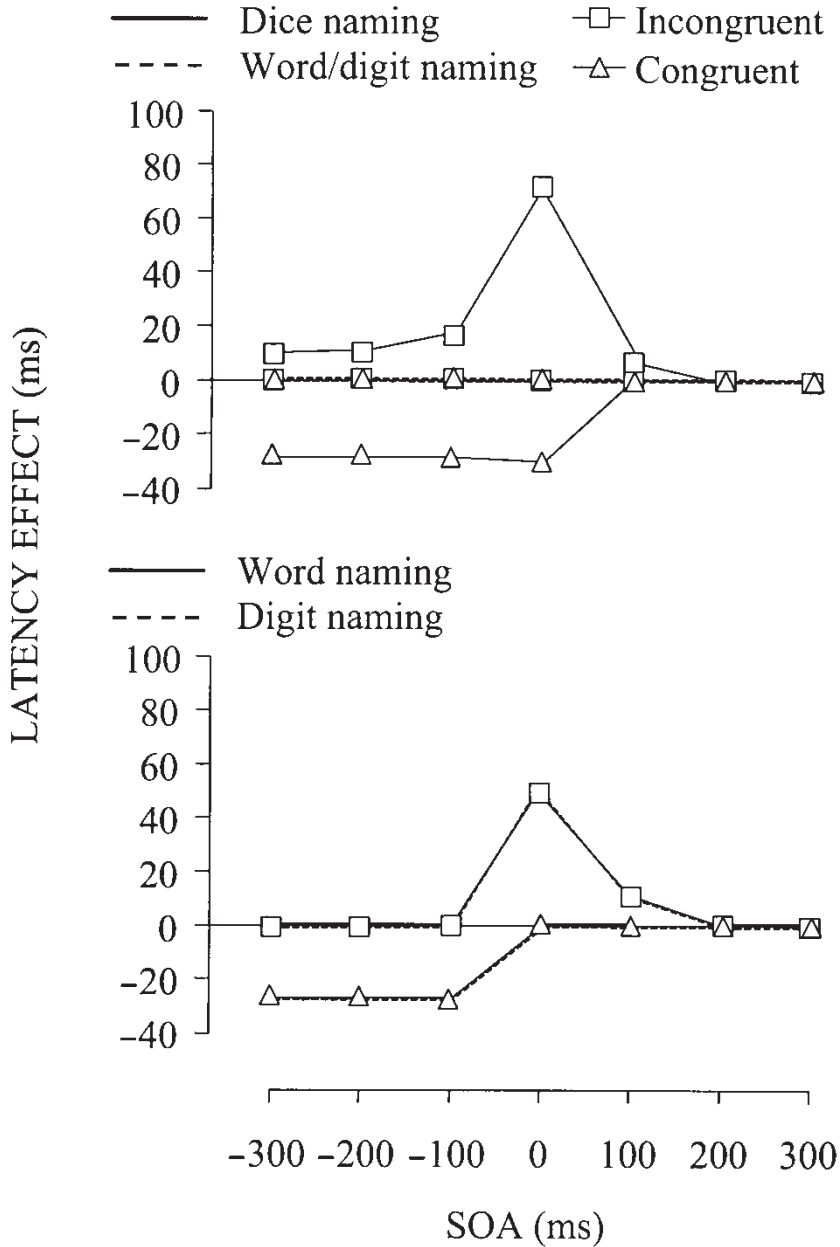

**Figure 6.** Time course of the number Stroop effects observed in WEAVER++ simulations of Experiments 1, 2, and 3. Positive effects indicate interference and negative effects facilitation relative to the control condition.

Although there was general agreement between the real data of Experiments 1 and 3, there were also some noticeable differences between the experiments, which were not captured by the model. The size of the interference effects in dice naming differed between experiments and the facilitation occurred at the SOAs of  $-100$ ,  $0$ , and  $100$  ms in Experiment 3 but at the SOAs of  $-200$  and  $-300$  ms in Experiment 1. Whereas the model captured the general asymmetry in effects between the dice naming task and the word/digit naming tasks, it did not capture all the finer details of the SOA curves. The differences between data and model suggest that the model is incomplete.

Moreover, in the real data of Experiments 1 and 3, there was some influence of dice distractors on word/digit naming (i.e., there was interference at  $SOA = -200$  ms in Experiment 1 and there were trends at the distractor-first SOAs in Experiment 3), whereas the model produced no effects at all. What does this discrepancy between model and data mean? One possibility is that the assumption made for the model that digit/word naming in Stroop-like tasks is achieved exclusively by a shallow form-to-form mapping is too strong and that, instead, on some trials there is lemma-level involvement in the naming response. Moreover, at large distractor-first SOAs, response anticipation cannot be excluded (for a discussion, see Roelofs, 2003). Therefore, the most critical observation is that at the short SOAs around  $SOA = 0$  ms, no interference and facilitation was obtained from dice distractors on word naming and digit naming. The model agrees with this critical finding. An explanation of the interference from dice on word naming at  $SOA = -200$  ms in Experiment 1 in terms of naming via the lemma level or a response anticipation raises the question why there were no effects at the SOAs of  $-300$  and  $-100$  ms in Experiment 1 or at  $-200$  ms in Experiment 3? Why would the  $SOA = -200$  ms condition be one in which the participants arbitrarily decided to use lemma-driven naming or anticipate the response? Although the fact that SOA was run as a blocked factor made such a strategy possible, the absence of effects at the other SOAs would rather suggest that the effect at  $SOA = -200$  ms in Experiment 1 is just a Type I error.

Still, given that the model assumes that there exist different reading routes (i.e., form-driven vs. lemma-driven reading), one may expect to find differences between studies in the reading route adopted. Indeed, whereas Fias et al. (2001) obtained no effect of numerical distance between distractor digits and words in digit and word naming, which suggests form-driven reading, Reynvoet et al. (2002) observed that naming latencies were longer when the digits and words were numerically far than when they were numerically near, which suggests lemma-driven reading. As discussed in Roelofs (2003), lemma-driven reading in the model allows for

conceptual influences from distractors, whereas form-driven reading does not.

The lower panel of Figure 6 shows the results from simulations of Experiment 2. The solid lines give the results for word naming with digit distractors and the dashed lines give the results for digit naming with word distractors. Digit distractors yielded interference and facilitation in word naming, and word distractors yielded the same interference and facilitation in digit naming (the interference was about 20 ms smaller for digit/word naming than for dice naming in the model). Thus, different from dice naming with digit/word distractors and word naming with dice distractors, the patterns of effect are completely symmetrical between tasks, as empirically observed. Furthermore, the peak of the interference in the simulations of Experiment 2 was again around  $SOA = 0$  ms, as empirically observed.

## GENERAL DISCUSSION

Five number Stroop experiments examined whether digit naming is achieved like picture naming or like word naming. Speakers named dice faces, Arabic digits, or written number words, while simultaneously trying to ignore congruent or incongruent dice, digit, or number word distractors presented at different SOAs. Stroop-like interference and facilitation effects were obtained from digit and word distractors on dice naming, but not from dice distractors on digit and word naming. In contrast, word distractors affected digit naming and digit distractors affected word naming to the same extent. The peak of the interference was always around  $SOA = 0$  ms, whereas facilitation was constant across distractor preexposure SOAs. These results suggest that digit naming is achieved like word naming (the claim implemented in WEAVER++) rather than picture naming (as claimed by Fias et al., 2001). The experiments were not only designed to test whether digits are named like words or like pictures, but they were also designed to test the extension to spoken numeral production and number Stroop performance of WEAVER++. It was shown that WEAVER++ successfully simulated the key results.

The results of Experiments 2, 4, and 5 suggest that the physical size of the distractors caused the difference between the present results and those of Fias et al. (2001). When the size of a digit is the same as that of a single letter, word naming is not affected by digit distractors at  $SOA = 0$  ms but it is affected at  $SOA = -100$  ms. The size of the interference at the latter SOA is the same as the interference effect obtained for same-sized digits and words.

Physical size has also played a central role in tests of the account of Stroop-like effects advanced by Melara and Algom (2003), who showed

that Stroop-like effects can be manipulated by dimensional discriminability along with other factors such as correlation and uncertainty. Dimensional discriminability refers to the psychological difference separating stimulus values along a dimension. It is measured by the speed and accuracy to identify the values as they vary randomly from trial to trial. According to the dimensional discriminability account of Stroop-like effects, the more discriminable dimension interferes with the less discriminable dimension. Dimensional discriminability is assessed by measuring the response times to the value of one dimension while keeping the other dimension constant (e.g., the control condition in the present experiments). Dimensional discriminability is typically manipulated by increasing or decreasing the physical size of stimuli. Correlation of dimensions refers to the conditional probability of the value on one dimension given a value on the other dimension. With correlated target and distractor dimensions, participants have, in principle, a better-than-chance probability of identifying the target on the basis of the distractor. Correlated dimensions invite paying attention to the distractor, resulting in interference or facilitation. Finally, dimensional uncertainty refers to the number of values per dimension. A stimulus is more surprising with a large than a small number of values. A more surprising dimension better captures attention.

Dimensional discriminability would seem to be able to account for some of the findings of the present experiments. For example, naming dice was slower than naming words (Experiment 1) and digits (Experiment 3) in the control condition. In terms of the discriminability account, the more discriminable dimensions (words and digits) interfered with the less discriminable dimension (dice), but not vice versa. This raises the question whether dimensional discriminability, along with correlation and uncertainty, can provide an alternative, comprehensive account of the finding on number Stroop performance. This appears not to be possible. In particular, an account in terms of dimensional discriminability, correlation, and uncertainty disagrees with several aspects of the findings. In the digit/word naming experiment of Fias et al. (2001), distractor words in digit naming and distractor digits in word naming yielded asymmetrical effects even though the baseline discriminability was matched between digit and word naming. Moreover, in a second, odd/even (parity) judgement experiment by Fias et al. (2001), the baseline discriminabilities were not matched, but the difference between the congruent and incongruent conditions was the same for responding to digits and to words. In the present Experiment 2, distractor words in digit naming and distractor digits in word naming yielded symmetrical effects even though the baseline discriminability was not matched between digit and word naming. In particular, the baselines for naming in the two tasks differed by 35 ms (in the control conditions,  $F(1, 26) = 4.82$ ,  $MSE = 12450$ ,  $p < .037$ ), which was roughly equal to the

size of the interference (about 30 ms) in *both* word naming and digit naming. In Experiments 1–3, the dimensions were correlated in all tasks (there were 4 congruent stimuli repeated twice and 12 incongruent stimuli). Nevertheless, no interference was obtained from dice distractors on word naming (Experiment 1) and from dice distractors on digit naming (Experiment 3). Finally, the dimensional uncertainty was greater in Experiment 4 (where the stimuli ranged from 0–9) than in Experiment 2 (where they ranged from 1–4), but the interference was the same. Moreover, the dimensional uncertainty was matched between tasks *within* the experiments, but asymmetrical effects were obtained between tasks within Experiments 1 and 3. To conclude, dimensional discriminability, correlation, and uncertainty cannot provide an alternative, comprehensive account of the findings.

In conclusion, the present experiments examined whether digit naming is functionally achieved like dice naming or like word naming. Stroop-like interference and facilitation effects were obtained from digit and word distractors on dice naming, but not from dice distractors on digit and word naming. In contrast, word distractors affected digit naming and digit distractors affected word naming to the same extent. The peak of the interference was always around  $SOA = 0$  ms, whereas facilitation was constant at distractor preexposure SOAs. These results suggest that digit naming is achieved like word naming rather than dice naming.

## REFERENCES

- Baayen, R. H., Piepenbrock, R., & Gulikers, L. (1995). *The CELEX Lexical Database*. (CD-ROM). Philadelphia, PA: Linguistic Data Consortium.
- Brysbaert, M. (1995). Arabic number reading: On the nature of the numerical scale and the origin of phonological recoding. *Journal of Experimental Psychology: General*, *124*, 434–452.
- Bourdon, B. (1908). Sur le temps nécessaire pour nommer les nombres [On the time it takes to name numbers]. *Revue Philosophique de la France et de l'étranger*, *65*, 426–431.
- Bush, G., Luu, P., & Posner, M. I. (2000). Cognitive and emotional influences in anterior cingulate cortex. *Trends in Cognitive Sciences*, *4*, 215–222.
- Butterworth, B. (1999). *The mathematical brain*. London: Macmillan.
- Cattell, J. M. (1886). The time taken up by cerebral operations. *Mind*, *11*, 524–538.
- Coltheart, M., Rastle, K., Perry, C., Langdon, R., & Ziegler, J. (2001). DRC: A dual route cascaded model of visual word recognition and reading aloud. *Psychological Review*, *108*, 204–256.
- Deacon, T. W. (1997). *The symbolic species: The co-evolution of language and the brain*. New York: Norton.
- Deheane, S. (1992). Varieties of numerical abilities. *Cognition*, *44*, 1–42.
- Deheane, S. (1997). *The number sense: How the mind creates mathematics*. New York: Oxford University Press.
- Fias, W., Reynvoet, B., & Brysbaert, M. (2001). Are Arabic numerals processed as pictures in a Stroop interference task? *Psychological Research*, *65*, 242–249.

- Flowers, J. H., Warner, J. L., & Polansky, M. L. (1979). Response and encoding factors in "ignoring" irrelevant information. *Memory and Cognition*, 7, 86–94.
- Fox, L. A., Shor, R. E., & Steinman, R. J. (1971). Semantic gradients and interference in naming color, spatial direction and numerosity. *Journal of Experimental Psychology*, 91, 59–65.
- Gelman, R., & Gallistel, C. R. (1978). *The child's understanding of number*. Cambridge, MA: Harvard University Press.
- Glaser, W. R., & Dünghoff, F.-J. (1984). The time course of picture-word interference. *Journal of Experimental Psychology: Human Perception and Performance*, 10, 640–654.
- Glaser, M. O., & Glaser, W. R. (1982). Time course analysis of the Stroop phenomenon. *Journal of Experimental Psychology: Human Perception and Performance*, 8, 875–894.
- Glaser, W. R., & Glaser, M. O. (1989). Context effects in Stroop-like word and picture processing. *Journal of Experimental Psychology: General*, 118, 13–42.
- Hurford, J. R. (1987). *Language and number*. Oxford: Basil Blackwell.
- Ischebeck, A. (2003). Differences between digit naming and number word reading in a flanker task. *Memory and Cognition*, 31, 529–537.
- Levelt, W. J. M., Roelofs, A., & Meyer, A. S. (1999). A theory of lexical access in speech production. *Behavioral and Brain Sciences*, 22, 1–38.
- MacLeod, C. M. (1991). Half a century of research on the Stroop effect: An integrative review. *Psychological Bulletin*, 119, 163–203.
- MacLeod, C. M., & MacDonald, P. A. (2000). Interdimensional interference in the Stroop effect: Uncovering the cognitive and neural anatomy of attention. *Trends in Cognitive Sciences*, 4, 383–391.
- Melara, R. D., & Algom, D. (2003). Driven by information: A tectonic theory of Stroop effects. *Psychological Review*, 110, 422–471.
- McCloskey, M. (1992). Cognitive mechanisms in numerical processing. Evidence from acquired dyscalculia. *Cognition*, 44, 107–157.
- Meeuwissen, M., Roelofs, A., & Levelt, M. J. M. (2003). Planning levels in naming and reading complex numerals. *Memory and Cognition*, 31, 1238–1249.
- Neely, J. H. (1991). Semantic priming effects in visual word recognition: A selective review of current findings and theories. In D. Besner & G. W. Humphreys (Eds.), *Basic processes in reading: Visual word recognition* (pp. 264–336). Hillsdale, NJ: Lawrence Erlbaum Associates Inc.
- Pavese, A., & Umiltà, C. (1998). Symbolic distance between numerosity and identity modulates Stroop interference. *Journal of Experimental Psychology: Human Perception and Performance*, 24, 1535–1545.
- Reynvoet, B., Brysbaert, M., & Fias, W. (2002). Semantic priming in number naming. *Quarterly Journal of Experimental Psychology*, 55A, 1127–1139.
- Roelofs, A. (1992). A spreading-activation theory of lemma retrieval in speaking. *Cognition*, 42, 107–142.
- Roelofs, A. (1997). The WEAVER model of word-form encoding in speech production. *Cognition*, 64, 249–284.
- Roelofs, A. (2003). Goal-referenced selection of verbal action: Modeling attentional control in the Stroop task. *Psychological Review*, 110, 88–125.
- Roelofs, A., & Hagoort, P. (2002). Control of language use: Cognitive modeling of the hemodynamics of Stroop task performance. *Cognitive Brain Research*, 15, 85–97.
- Smith, M. C., & Magee, L. E. (1980). Tracing the time course of picture-word processing. *Journal of Experimental Psychology: General*, 109, 373–392.
- Stroop, J. R. (1935). Studies of interference in serial verbal reactions. *Journal of Experimental Psychology*, 18, 643–662.

- Theios, J. & Amrhein, P. C. (1989). Theoretical analysis of the cognitive processing of lexical and pictorial stimuli: Reading, naming, and visual and conceptual comparisons. *Psychological Review*, 96, 5–24.
- Vorberg, D. (1985). Unerwartete Folgen von Zufälliger Variabilität: Wettlauf-Modelle für den Stroop-Versuch [Unexpected consequences of random variability: Race models for the Stroop task]. *Zeitschrift für experimentelle und angewandte Psychologie*, 32, 494–521.
- Windes, J. D. (1968). Reaction time for numerical coding and naming numerals. *Journal of Experimental Psychology*, 78, 318–322.